

SUPER DOME

- › VANDALPROOF DOME CAMERA
- › DAY & NIGHT
- › 3.5-8MM AUTO-IRIS VARIFOCAL LENS
- › CONDUIT OPENING PROVIDED
- › METAL HOUSING
- › IP66 RATED



MODEL#: SUPER DOME

Here is a Vandal Proof Day/Night Dome Camera for less than \$100! It comes standard with a metal housing, a varifocal lens, and conduit opening. Put it inside offices, hallways, even outside to get a crystal clear picture day or night.

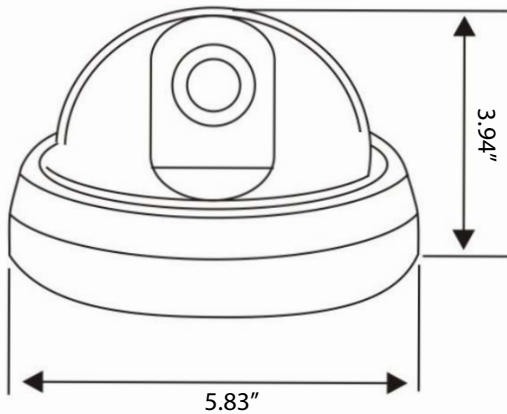
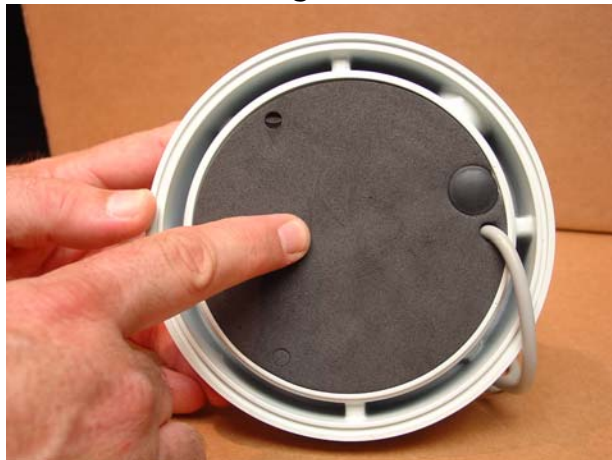

Image sensor	1/3" Sony Super HAD CCD II
Effective Pixels	NTSC : 768(H) x 494 (V)
Horizontal Resolution	NTSC : 540 TV Lines
Scanning system	2:1 Interlaced
Synchronizing system	Internal
Minimum Illumination	0.1Lux
Lens	Built-in 3.5 ~ 8mm Auto Iris Varifocal Lens
Back Light Compensation	Auto
White Balance	Auto
Gain Control	Auto
Electronic Shutter	NTSC : 1/60~1/100,000 sec.
S/N ratio	More than 50dB (AGC Off)
Gamma correction	>0.45
Video output	1.0 Vp-p Composite Signal (75ohm)
Operation Temperature	-10°C - +50°C
Operation Humidity	Within 95% RH
Power Supply	DC12V (+/-15%)
Dimensions (inches)	5.83"(L) X 5.83"(W) X 3.94"(H)
Weight-Net (Approx lbs.)	2.23lbs

Gasketed Mounting Surface



Mounting Anchors