

Speed Dome Camera Controller

Operation Manual



Please read this operation manual before using this device and use the device properly.

Also, please keep this manual with care to ensure easy access at any time.

I. Brief introduction

The keyboard controller is used for terminal receivers such as the intelligent Speed Dome and the decoder etc. Taking the EIA/RS-485 electrical interface between the keyboard and the receiver, one keyboard can control as much as 32 speed dome and decoders without driving the bus and the maximum communication distance between the keyboard and the receiver is up to 1.2 km. It's very easy for operating and setting the Speed Dome Camera. The controller is also to control the terminal receiver to achieve the function of controlling pan/tilt, lens and ect.

Main Functions:

- ◆ Set the address range of the dome camera and the decoder: 0~255.
- ◆ Control all functions of the dome camera such as Power ON/OFF.
- ◆ To operate the pan/tilt of Speed Dome Camera moving in different speed lever
- ◆ Set or call the set points and cruise tracks of the dome camera. Altogether 128 preset points and 6 cruise tracks can be set. Each track involves 16 preset position and the dwelling time and call speed upon each point can be set as well.
- ◆ Manually or automatically control the dome camera, and change the leaving settings of particular camera by call the menu of the camera. .
- ◆ Manually control the focus, zoom and iris of the camera.

II. Introduction of Functions:

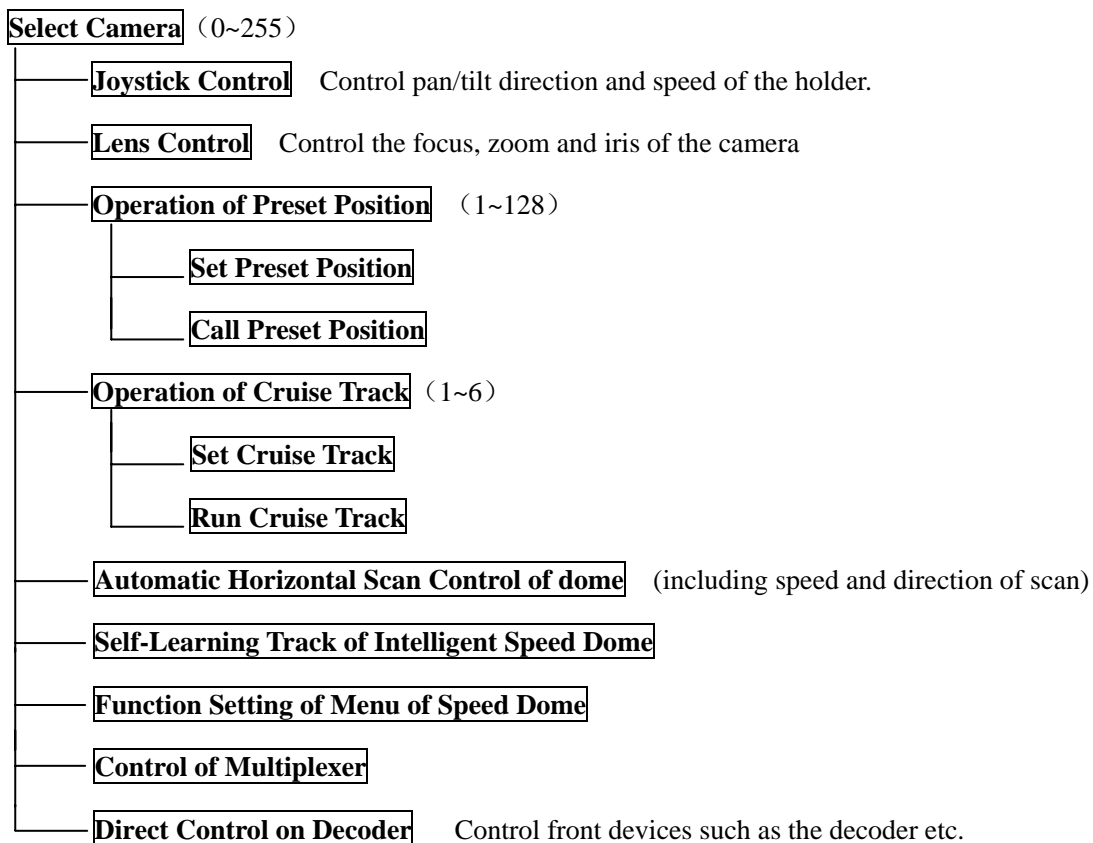

III. Introduction of the keyboard Panel

1. The Sketch of the Front Panel and Description of Buttons (Figure 1)

There are speed joystick, buttons and LCD on the front panel of the control keyboard. The display is used to show the status of the system as well as operation information. The joystick controls the upward, downward, leftward and right ward speed motion of the speed dome. The description of buttons is as follows:

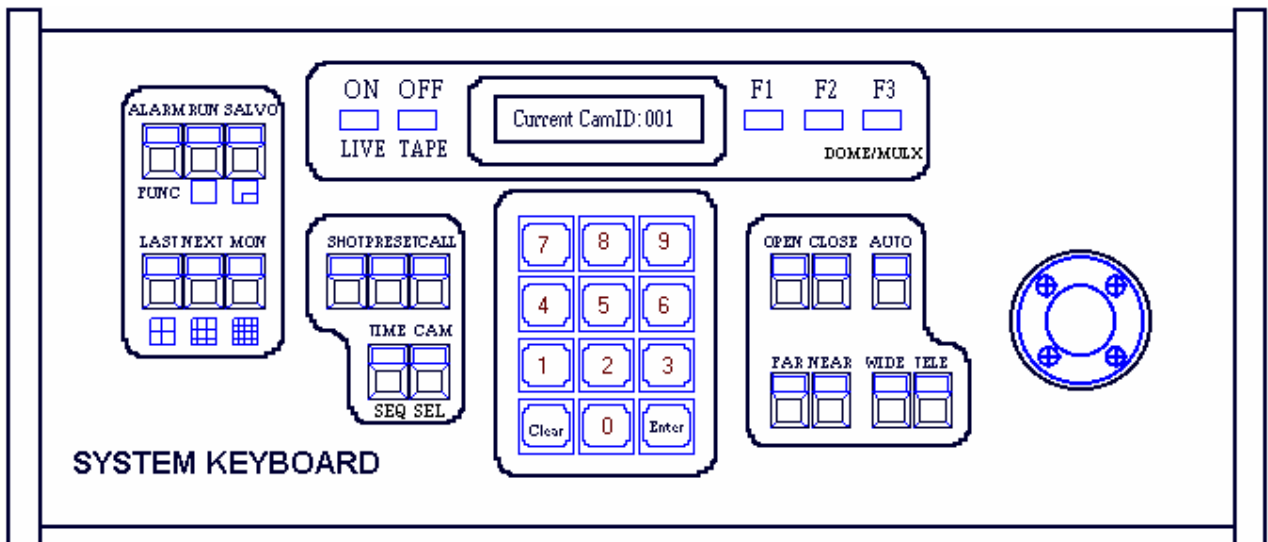

(Figure 1)

- **Func (1 cam):** Set special function of the system together with other buttons.
- **Zoom (Full screen):** Show picture of the camera in full screen.
- **PIP (up arrow):** Show picture of the camera in PIP mode (Picture-in-Picture).
- **2×2 (down arrow):** Show picture of the camera in 4-frame.
- **3×3 (left arrow):** Show picture of the camera in 9-frame.
- **4×4 (right arrow):** Show picture of the camera in 16-frame.
- **Live:** Show live picture of the camera at current mode.
- **Tape:** Playback pictures; **Function + Tape:** Playback video information of VCR.
- **CAM:** Select address of the intelligent Speed Dome or multiplexer.
- **CALL:** To call the preset position.
- **PRESET:** To set the preset position.
- **SHOT:** To set up or call cruising track.
- **TIME:** Set time for special function.
- **AUTO:** To control auto-horizontal rotation for pan/tilt.
- **WIDE:** To a wide angle.
- **TELE:** To turn to a telescopic range.
- **FAR:** To make focus far manually.
- **NEAR:** To make focus near manually.
- **OPEN:** To open iris.
- **CLOSE:** To close iris.
- **ON:** Switch on the setting of function.
- **OFF:** Switch off the setting of function.
- **F1/F2:** Auxiliary control buttons.
- **F3:** Switching control between intelligent Speed Dome and Multiplexer.
- **0-9:** Number key
- **CLEAR:** To clear inputted data
- **ENTER:** To confirm

2. Rear Panel (Figure 2)

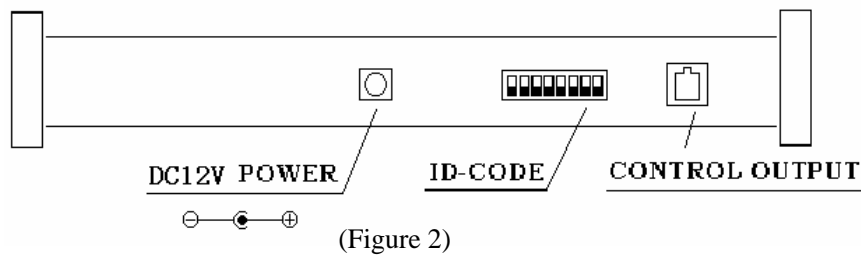

- A. Power input connector: input DC12V power.
- B. ID-Code switch: Used to set the protocol in use and the baud rate of communications.
- C. Communication connector RS485: The controller is connected to adapter box by specific cable.

IV. Setting of the Keyboard

- a) The protocol in use and the baud rate of communication of the keyboard are set by the ID-Code in Figure 2. DIP1-DIP4 are used to select type of the communication protocol as per following table (● means the protocol is available):

Type of Protocols	Selection of Protocols				Normal Baud Rate		Integrated Protocol
	DIP1	DIP2	DIP3	DIP4	DIP5	DIP6	
Minking A01	OFF	OFF	OFF	OFF	ON	OFF	●
Minking B01	ON	OFF	OFF	OFF	OFF	ON	●
Santachi	OFF	ON	OFF	OFF	OFF	ON	●
PELCO-D	ON	ON	OFF	OFF	OFF	OFF	●
PELCO-P/4800Bps	OFF	OFF	ON	OFF	ON	OFF	●
PELCO-P/9600Bps					OFF	ON	●
PANASONIC	ON	OFF	ON	OFF	OFF	ON	●
Longcomity	OFF	ON	ON	OFF	OFF	ON	○
HUNDA600	ON	ON	ON	OFF	OFF	ON	●
LILIN	OFF	OFF	OFF	ON	OFF	ON	●
VICON	ON	OFF	OFF	ON	ON	OFF	●
MOLYNX	OFF	ON	OFF	ON	OFF	ON	○
KALATEL	ON	ON	OFF	ON	ON	OFF	●
VCL	OFF	OFF	ON	ON	OFF	ON	○
Reserved	ON	OFF	ON	ON	OFF	ON	○
ALEC	OFF	ON	ON	ON	OFF	ON	●
Ultrak	ON	ON	ON	ON	OFF	ON	●

- b) DIP5 and DIP6 are used to select the baud rate, shown as following table(DIP7 and DIP8 are not used):

Status of ID-Code	DIP1	DIP2	DIP3	DIP4	DIP5	DIP6	DIP7	DIP8
Baud Rate								
2400bps					OFF	OFF		
4800bps					ON	OFF		
9600bps					OFF	ON		
19200bps					ON	ON		

c) Some of the ID-Code of the protocols are set as follows:

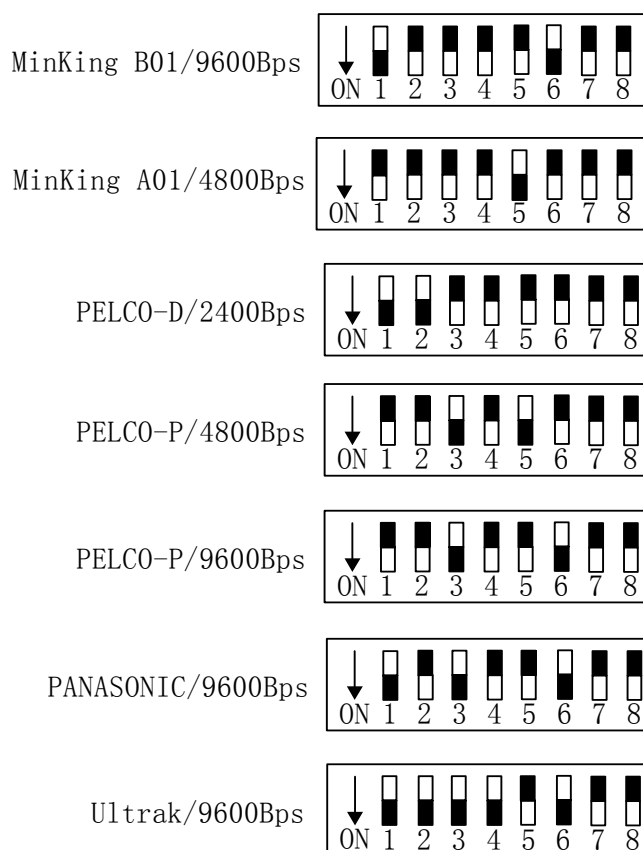

d) **Switching control between intelligent decoder and multiplexer.:** The keyboard can be operated in two modes: Intelligent Decoder and Multiplexer. When power supply is on it is operated on the default mode of Intelligent Decoder. Press [F3] down until the LCD display "CONTROLLING MULX", then control the processor by the RS-232 output of the keyboard. **Attention!** If the LCD is not the right state, the Multiplexer can not be under of control.

V. Operation of the Keyboard

1. Select Address of Speed Dome Camera /Decoder: [CAM]+[N]+[Enter]

Display: Current CamID: 001

Description: N — No. of camera from 0 to 255

Function: Select the address of the camera to be controlled. When the value N is in conformity with the address of the speed dome, it will be under control.

2. To set preset position: [PRESET]+[N]+[Enter]

Display: Preset No: 001

Description: N — No. of preset position from 1 to 128.

Function: Store current position and refer it as No. N position.

3. Call the Preset position: [CALL]+[N]+[Enter]

Display: Call Number: 001

Description: N — No. of preset position from 1 to 128.

Function: Transfer the camera to the position of No. N preset position.

4. Cancel the Preset position:[PRESET]+[N]+[OFF]

Display: Preset No: 001

Description: N — No. of preset position from 1 to 128.

Function: Delete the No. N Preset position stored.

5. Set the cruise track (Minking A01/B01、PELCO-P、PELCO-D、ALEC、Ultrak Available)

- Enter the status of track setting: **[SHOT]+[N]+ [ON]** (N: No. of track from 1 to 6).

Display:

Track = 01	Sum = 06
------------	----------

Description: Track No1 is currently set, in which there are 6 preset points.

- Edit Track: Press **[TELE]** to edit afterward and press **[WIDE]** to edit return. Each track involves 16 preset points and the running speed and the dwelling time of each preset position.

Display:

No.: 01	Point: 001
---------	------------

 → Description: The 1st preset position in the track is 01.

Display:

No.: 01	Speed: 001
---------	------------

 → Description: The speed of the 1st preset point in the track is the 1st class.

Display:

No.: 01	Time: 004
---------	-----------

 → Description: The dwelling time of the 1st preset point in the track is 4 seconds

- Speed Range: 1 to 8 from the fastest to the lowest. Any speed outside the range will be referred as the 1st class; the range of the dwelling time is: 1 to 99.
- When the No. N preset point is set as No. 0, then all preset points before the No. N preset point in the track will be valid however all numbers of preset points afterward and their speed and dwelling time shall be set as 0 automatically.
- After tracks are edited, press OFF to store and exit while push the joystick to exit without storage.

6. Tour the Track: **[SHOT]+[N]+ [Enter]**

Display:

Input Tour No: 01

Description: N — No. of the track from 1 to 6.

Function: Tour the No. N track and stop tour by pushing the joystick.

7. Stop the Track: **[SHOT]+[N]+ [OFF]**

Display:

Input Tour No: 01

Description: N — No. of the track from 1 to 6.

Function: Stop the No. N track or stop tour by pushing the joystick.

8. Cancel Cruise Track: **[SHOT]+[N]+ [OFF]** (Pressing **[OFF]** down until “**Clear Tour OK**” appears)

Display:

Input Tour No: 01

Description: N — No. of the track from 1 to 6.

Function: Delete the No. N track

9. To turn on Auto Pan (Operation of NEON、SAMSUNG Protocol): **[AUTO]+[P1]+[ON]+[P2]+[OFF]**

Display:

Input 1st No: 001

Description: P1 — the starting scan No. of preset point from 1 to 128, which should be set already.

Display:

Input 2nd No: 002

Description: P2 – the ending scan No. of preset point from 1 to 128, which should be set already. If P1 = P2 or P1 and P2 are coincided, the speed dome will make scan in range of 360°.

Note:① For PELCO-D、PELCO-P Protocol the way of operation is as follows:

- ◆ Set the starting scan position: Transfer the Speed Dome to the starting scan position, operation **[AUTO]+[ON]**
- ◆ Set the ending scan position: Transfer the Speed Dome to the ending scan position, operation **[AUTO]+[OFF]**
- ◆ Run Auto Pan: **[AUTO]+[ENTER]**

②Auto Pan operation takes the following parameters. You must set these parameters before using a Auto Pan command to begin the scan operation. You can use the scan stop command or PT scan stop command to stop the scan. Setting scan condition.

- Auto Pan Position(First specify position, second specify position)
- Auto Pan Speed and Direction

10. Stop Auto Pan: **[AUTO]+[OFF]**(Only Minking A01、 B01 Available) or push the joystick to stop scan
11. Control the zoom of the Camera: **[WIDE]/[TELE]**
12. Control the Focus of the Camera: **[FAR]/[NEAR]**
13. Control the Iris of the Camera: **[OPEN]/[CLOSE]**
14. Auxiliary Control of the Camera: By combination of **[F1]** and **[ON]**, **[OFF]** buttons, you can set some data of the camera, and functions are listed as follows(operations of NEON Protocol):

No. of Value N	Control Object	Definition of Keyboard Operation	
		[F1]+N+[ON]	[F1]+N+[OFF]
0	Camera power supply/reset control	Power ON/OFF Switching	Recover Initial Values of Camera
1	Back Light Compensation	ON	OFF
2	Zero Illumination (refer to function of camera)	ON	OFF
3	Menu/Display (refer to function of camera)	ON	OFF
4	Digital Zoom	ON	OFF
5	Back Light of Keyboard Screen	ON	OFF
6	Focus	Automatic	Manual
7	Iris	Automatic	Manual
8	White Balance Mode (WB)	Automatic	Manual
9		Indoor Mode	Outdoor Mode
10		ATW Mode	One Push WB
11	Black & White/Color Switching	Color	Black & White
12	Set Auto Pan (Only conditions for scan. If start scan, operate as Item 6 in this paragraph)	< 180°, low speed	> 180°, low speed
13		< 180°, middle speed	> 180°, middle speed
14		< 180°, high speed	> 180°, high speed
15	Reserved		
16	Reserved		
17	Reserved		
18	Reserved		

- For different camera, control functions in the list could be different.
- For the camera with the menu, switch ON/OFF the menu by “**[F1]+[3]+[ON]**”, and switch ON/OFF the OSD by “**[F1]+[3]+[OFF]**”. In case the camera has the menu and the menu is ON:
 1. Select the item on the menu by buttons **[WIDE]/[TELE]** to scroll the cursor up or down;
 2. Chang the status of the selected item on the menu by buttons **[FAR]/[NEAR]**;
 3. Switch OFF the menu as per operations in the list after the menu is set.
- Take care of differences between the **Menu of Speed Dome** and the **Menu of Camera**. For the speed dome with the menu, enter the menu by “**[CALL]+[64]+[Enter]**” and basic operations are as follows:
 1. Call No.64 preset point to open the main menu by the control keyboard.
 2. When the menu appears on the screen, move the cursor to the item you need to set by “**TILT UP**” and “**TILT DOWN**”, and enter the settings of the item to make change by “**PAN LEFT**” and “**PAN RIGHT**”;
 3. Speed up operation of the joystick after keeping it for one second in one direction.
 4. All settings of the menu could not be lost even power failure occurred;
 5. Operations under special case can be referred

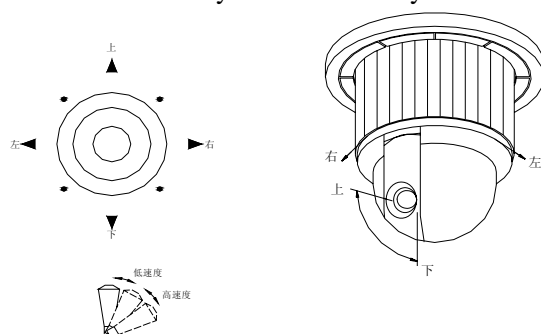

Figure3

on the description of the menu of the ball machine.

15. Use the Joystick to Control the Speed Dome Camera:

You can use the speed joystick to control the Pan/Tilt direction and speed of the dome of the camera randomly. The speed of pan/tilt is decided by the angle of the joystick you operated (Figure 3). Change the tilting angle of the joystick you can adjust the speed evenly and the camera can be focused automatically in the course of scan to keep images being distinct.

16. In case error operation occurs, normal display will be recovered after “Error Operation” appears for 1 second.

VI. Installation and Connection:

Attention: Please read the operation manual of the keyboard and the speed dome carefully before connecting wires. Any incorrect connections can cause permanent damage of the device. When connecting wires, first switch off the power supply of all devices. The communication wires between devices should be shielded twisted cable. When installing cables they should be far away from high voltage lines or other possible interference circuits as can as possible.

1. The marking of wires of the transfer box(Figure 4)
2. Connections of the keyboard controller controlling multiple speed dome cameras(figure5)

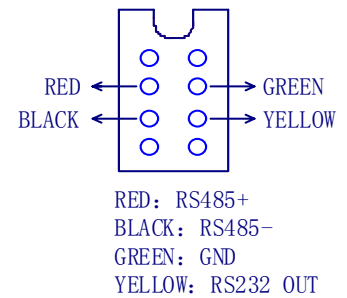

Figure 4

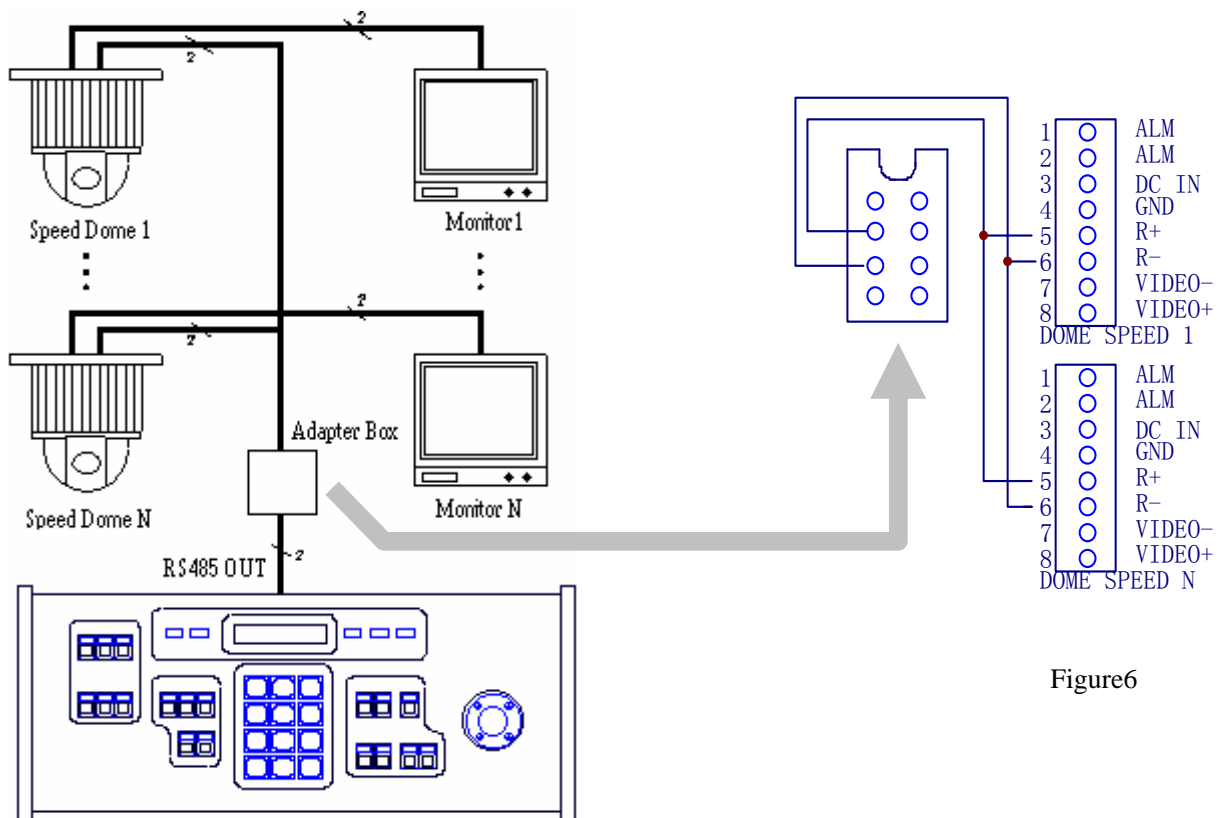

Figure5

Figure6

3. Connections between the keyboard and the speed dome camera(Figure6)
4. The keyboard controls the Multiplexer directly(Figure7)

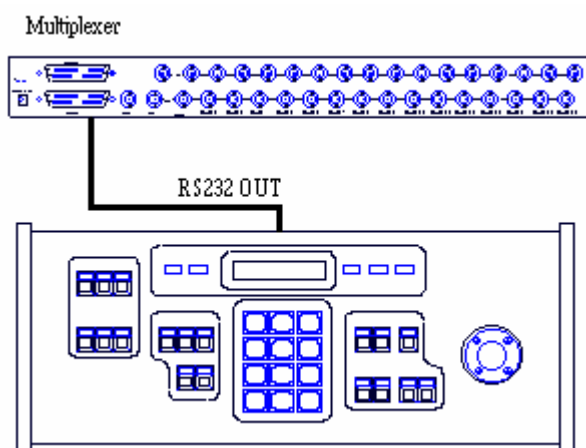

Figure7

VII. Technical Specifications:

- ◆ Communication between Speed Dome Camera and Controller: Port to multi-port and half duplex function.
- ◆ Communication connector: RS-485.
- ◆ Baud Rate of Communication: Four baud rates i.e. 2400Bps, 4800Bps, 9600Bps and 19200Bps.
- ◆ Distance of Communication: 1200 M in maximum
- ◆ Power Supply: DC12V/800 mA
- ◆ Size: 380 × 165 × 80 (mm)
- ◆ Weight: 2 Kg
- ◆ Number of Controlled Speed Dome Camera up to 32.

VIII. Points for Attention:

- ◆ Please read the operation manual of the keyboard carefully before using it.
- ◆ The operation manual is mainly focused on all functions of **B01 Protocol**. For other different protocols, operations could be something difference and those different parts will be listed on “**Supplementary Description of the Keyboard Controller**” in details.
- ◆ The keyboard takes 12V DC power supply. Please confirm the voltage and polarity before the power supply is switched on.
- ◆ Do not place the keyboard under the rain or on wet place so as to avoid short circuit or electrical shock.
- ◆ As the keyboard is a sophisticated electronic device, you should never open the case so as to avoid the occurrence of trouble.
- ◆ The keyboard has integrated multiple protocols, and you are pleased to select correct protocol and the baud rate. When switching on power supply, take care of the selected protocol and the baud rate on the first screen.
- ◆ In case the keyboard controls the Multiplexer, the operation of combination buttons is as follows: Press one button first, and press the other button after release the first one.
For example: When enter/exit setting of the menu (**Function + Zoom**), press **Function** button first, and press **Zoom** button after **Function** button is released.
- ◆ In case the keyboard controls the multiplexer, the operation of combination buttons is as follows: Press one button first, and press the other button after release the first one. While use **Function** alone, please put it down, until “Motion Detect OK” appears.
- ◆ When the keyboard controls the Multiplexer, please refer to concerned operation manual of Multiplexer