



Speed Dome Camera Controller

Operation Manual

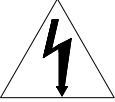

Please read this operation manual before using this device and use the device properly.
Also, please keep this manual with care to ensure easy access at any time.

SAFETY PRECAUTIONS

	CAUTION RISK OF ELECTRIC SHOCK. DO NOT OPEN!	
CAUTION: TO REDUCE THE RISK OF ELECTRICAL SHOCK, DO NOT OPEN COVERS. NO USER SERVICEABLE PARTS INSIDE. REFER SERVICING TO QUALIFIED SERVICE PERSONNEL		

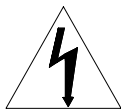

The lighting flash with a arrowhead symbol, in an equilateral triangle, is intended to alert the user. There is uninsulated “dangerous voltage” presence near by the product’s enclosure which may be risk of to persons .



The exclamation point within an equilateral triangle is intended to alert the user to reference of the important operating and maintenance (servicing) instructions .

THE PRODUCT CODE MARKED ON THE BOTTOM COVER. PLEASE FILL THE CODE IN THE FOLLOWING BLANK. PLEASE SAVING THIS SPECIFICATION CAREFULLY, SO THAT CHECKING

MODEL: _____

PRODUCT CODE: _____

INDEX

I. Summary.....	3
II. Introduction of Function.....	3
III. Introduction of the Keyboard's Panel.....	3
IV. Setting of the Keyboard.....	4
V. Operation of the Keyboard.....	5
VI. Installation and Connection.....	7
VII. Technical Specifications.....	8
VIII. Points for Attention.....	8

I. Summary

The keyboard controller is used for terminal receivers such as the intelligent Speed Dome and the decoder etc. Taking the EIA/RS-485 electrical interface between the keyboard and the receiver, one keyboard can control as much as 32 speed dome and decoders without driving the bus and the maximum communication distance between the keyboard and the receiver is up to 1.2 km. It's very easy for operating and setting the Speed Dome Camera. The controller is also to control the terminal receiver to achieve the function of controlling pan/tilt, lens and etc.

Main Functions:

- ◆ Set the address range of the dome camera and the decoder: 0~64.
- ◆ Control all functions of the dome camera such as Power ON/OFF.
- ◆ To operate the pan/tilt of Speed Dome Camera moving in different speed lever
- ◆ Set or call the points of the dome camera. Altogether 64 preset points can be set.
- ◆ Manually or automatically control the dome camera, and change the settings of particular camera by call the menu of the camera.
- ◆ Manually control the focus, zoom and iris of the camera.

II. Introduction of Functions:

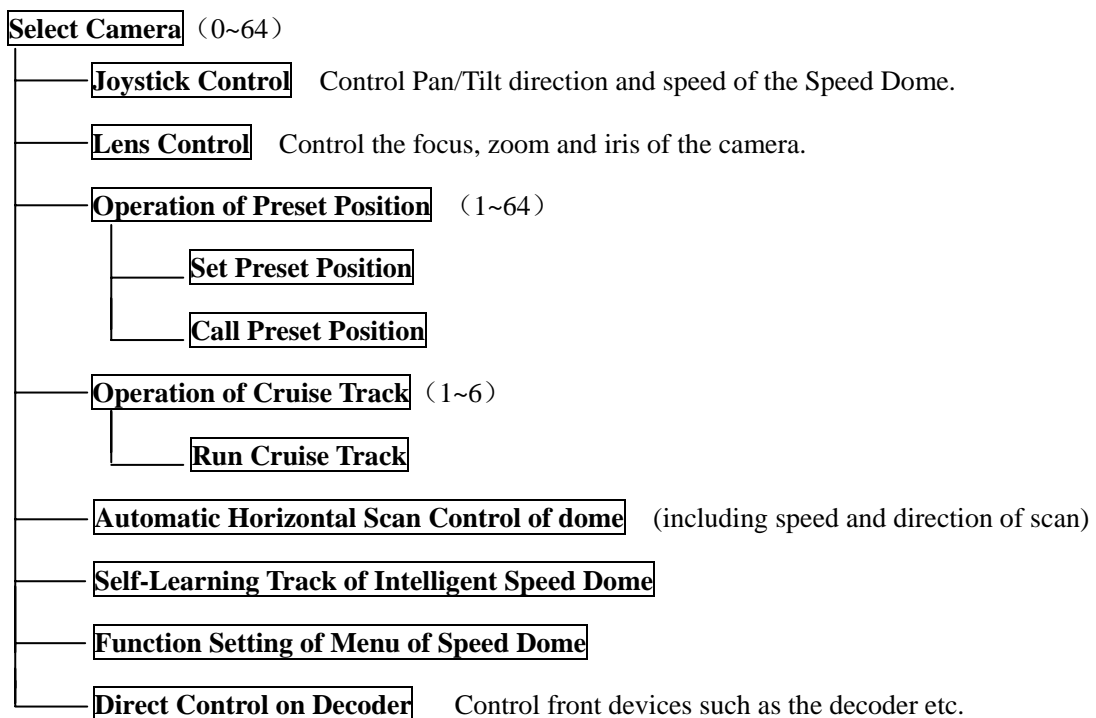

III. Introduction of the keyboard Panel

1. The Sketch of the Front Panel and Description of Buttons (Figure 1)

There are speed joystick, buttons and nixie light on the front panel of the control keyboard. The display is used to show the address of the speed dome as well as the number inputted. The joystick controls the upward, downward, leftward and right ward speed motion of the speed dome. The description of buttons is as follows:

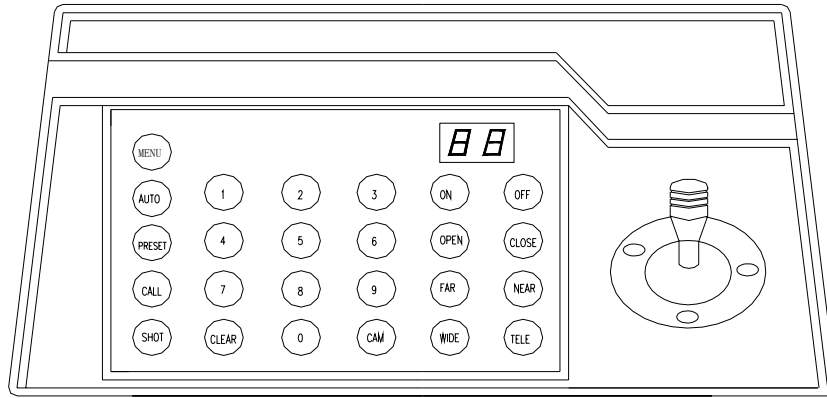
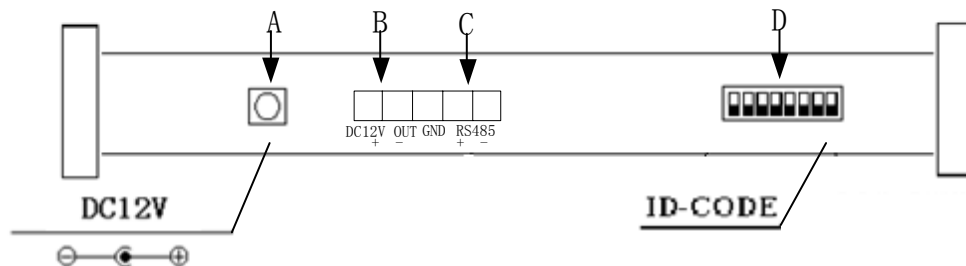

Figure 1

- **CAM:** Select address of the intelligent Speed Dome .
- **MENU:** Auxiliary control buttons.
- **AUTO:** To control auto-horizontal rotation for pan/tilt.
- **CLEAR:** To clear inputted data
- **0-9:** Number key
- **WIDE:** To a wide angle.
- **TELE:** To turn to a telescopic range.
- **FAR:** To make focus far manually.
- **NEAR:** To make focus near manually.
- **OPEN:** To open iris.
- **CLOSE:** To close iris.
- **ON:** Switch on the setting of function.
- **OFF:** Switch off the setting of function.
- **CALL:** To call the preset position.
- **PRESET:** To set the preset position.
- **SHOT:** To call cruising track.

2. Rear Panel (Figure 2)



- A. Power input connector: input DC12V power.
- B. DC12V Output.
- C. Communication connector RS485:
- D. ID-Code switch: Used to set the protocol in use and the baud rate of communications.

IV. Setting of the Keyboard

- a) The protocol in use and the baud rate of communication of the keyboard are set by the

ID-Code in Figure 2. DIP1-DIP4 are used to select type of the communication protocol as per following table

State of ID-CODE Type of Protocol	Setting of Protocol Type				Setting of default Baud Rate	
	DIP1	DIP2	DIP3	DIP4	DIP5	DIP6
A01	OFF	OFF	OFF	OFF	ON	OFF
NEON	ON	OFF	OFF	OFF	OFF	ON
B01	ON	OFF	OFF	OFF	OFF	ON
SAMSUNG	ON	OFF	OFF	OFF	OFF	ON
Santachi	OFF	ON	OFF	OFF	OFF	ON
PELCO-D	ON	ON	OFF	OFF	OFF	OFF
PELCO-P/4800Bps	OFF	OFF	ON	OFF	ON	OFF
PELCO-P/9600Bps					OFF	ON
HUNDA600	ON	ON	ON	OFF	OFF	ON

b) DIP5 and DIP6 are used to select the baud rate, shown as following table(DIP7 and DIP8 are not used):

Status of ID-Code Baud Rate	DIP1	DIP2	DIP3	DIP4	DIP5	DIP6	DIP7	DIP8
2400bps					OFF	OFF		
4800bps					ON	OFF		
9600bps					OFF	ON		
19200bps					ON	ON		

c) Some of the ID-Code of the protocols are set as follows:

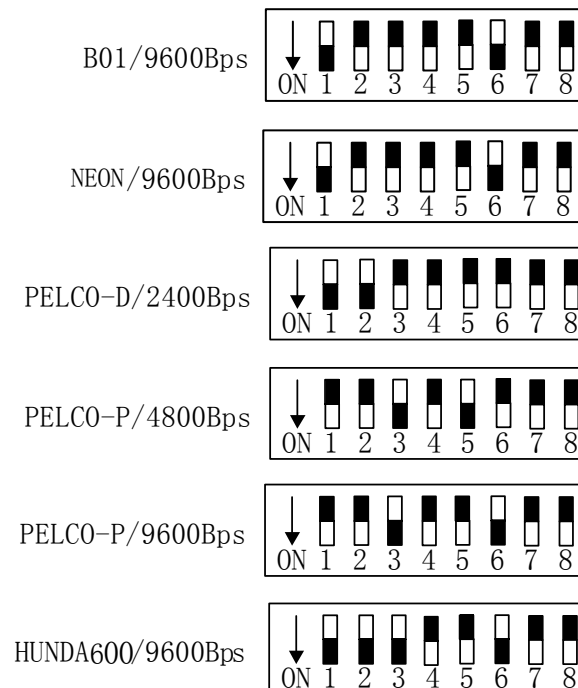

V. Operation of the Keyboard

1. Select Address of Speed Dome Camera /Decoder: **[N]+[CAM]**
 Description: N — No. of camera from 0 to 64
 Function: Select the address of the camera to be controlled. When the value N is in conformity with the address of the speed dome, it will be under control.
2. To set preset position: **[N]+[PRESET]**
 Description: N — No. of preset position from 1 to 64.
 Function: Store current position and refer it as No. N position.
3. Call the Preset position: **[N]+[CALL]**
 Description: N — No. of preset position from 1 to 64.
 Function: Transfer the camera to the position of No. N preset position.
4. Cancel the Preset position: **[N]+[CLEAR]**
 Description: N — No. of preset position from 1 to 64.
 Function: Delete the No. N Preset position stored.
5. Tour the Track: **[N]+[SHOT]**
 Description: N — No. of the track from 1 to 6.
 Function: Tour the No. N track and stop tour by pushing the joystick.
6. To turn on Auto Pan (Operation of NEON、SAMSUNG Protocol): **[AUTO]+[P1]+[ON]+[P2]+[OFF]**
 Description: P1 — the starting scan No. of preset point from 1 to 64, which should be set already.
 Description: P2 – the ending scan No. of preset point from 1 to 64, which should be set already. If P1 = P2 or P1 and P2 are coincided, the speed dome will make scan in range of 360°.
 Note:① For PELCO-D、PELCO-P Protocol the way of operation is as follows:
 - ◆ Set the starting scan position: Transfer the Speed Dome to the starting scan position, operation **[AUTO]+[ON]**
 - ◆ Set the ending scan position: Transfer the Speed Dome to the ending scan position,operation **[AUTO]+[OFF]**
 - ◆ Run Auto Pan: **[AUTO]+[SHOT]**
 ②Auto Pan operation takes the following parameters. You must set these parameters before using a Auto Pan command to begin the scan operation. You can use the scan stop command or PT scan stop command to stop the scan. Setting scan condition.
 - Auto Pan Position(First specify position, second specify position)
 - Auto Pan Speed and Direction
7. Stop Auto Pan: **[AUTO]+[OFF]**(Only A01、B01 Available) or push the joystick to stop scan
8. Control the zoom of the Camera: **[WIDE]/[TELE]**
9. Control the Focus of the Camera: **[FAR]/[NEAR]**
10. Control the Iris of the Camera: **[OPEN]/[CLOSE]**
11. Auxiliary Control of the Camera: By combination of **[MENU]** and **[ON]**, **[OFF]** buttons, you can set some data of the camera, and functions are listed as follows(operations of NEON Protocol):

No. of Value N	Control Object	Definition of Keyboard Operation	
		[MENU]+N+[ON]	[MENU]+N+[OFF]
0	Camera power supply/reset control	Power ON/OFF Switching	Recover Initial Values of Camera
1	Back Light Compensation	ON	OFF
2	Zero Illumination (refer to function of camera)	ON	OFF

3	Menu/Display (refer to function of camera)	ON	OFF
4	Digital Zoom	ON	OFF
5	Reserved		
6	Focus	Automatic	Manual
7	Iris	Automatic	Manual
8	White Balance Mode (WB)	Automatic	Manual
9		Indoor Mode	Outdoor Mode
10		ATW Mode	One Push WB
11	Black & White/Color Switching	Color	Black & White
12	Set Auto Pan (Only conditions for scan. If start scan, operate as Item 6 in this paragraph)	< 180°, low speed	> 180°, low speed
13		< 180°, middle speed	> 180°, middle speed
14		< 180°, high speed	> 180°, high speed
15	Reserved		
16	Reserved		
17	Self-learning of track programming	Start Programming	End Programming
18	Control of self-learning of track	Run	Move joystick to stop

- For different camera, control functions in the list could be different.
- For the camera with the menu, switch ON/OFF the menu by “[MENU]+[3]+[ON]”, and switch ON/OFF the OSD by “[MENU]+[3]+[OFF]”. In case the camera has the menu and the menu is ON:
 1. Select the item on the menu by buttons [WIDE]/[TELE] to scroll the cursor up or down;
 2. Change the status of the selected item on the menu by buttons [FAR]/[NEAR];
 3. Switch OFF the menu as per operations in the list after the menu is set.
- Take care of differences between the **Menu of Speed Dome** and the **Menu of Camera**. For the speed dome with the menu, enter the menu by “[64] +[CALL]” and basic operations are as follows:
 1. Call No.64 preset point to open the main menu by the control keyboard.
 2. When the menu appears on the screen, move the cursor to the item you need to set by “TILT UP” and “TILT DOWN”, and enter the settings of the item to make change by “PAN LEFT” and “PAN RIGHT”;
 3. Speed up operation of the joystick after keeping it for one second in one direction.
 4. All settings of the menu could not be lost even power failure occurred;
 5. Operations under special case can be referred on the description of the menu of the ball machine.

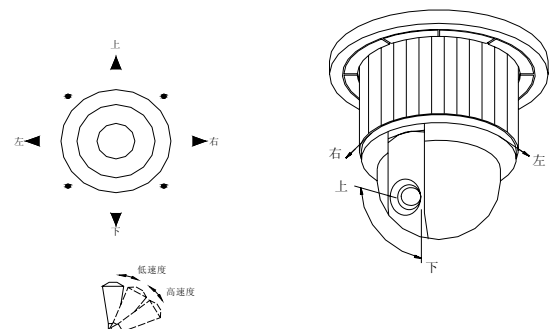

Figure3

12. Use the Joystick to Control the Speed Dome Camera:

You can use the speed joystick to control the Pan/Tilt direction and speed of the dome of the camera randomly. The speed of pan/tilt is decided by the angle of the joystick you operated (Figure 3). Change the tilting angle of the joystick you can adjust the speed evenly and the camera can be focused automatically in the course of scan to keep images being distinct.

VI. Installation and Connection

Attention: Please read the operation manual of the keyboard and the speed dome carefully before

connecting wires. Any incorrect connections can cause permanent damage of the device. When connecting wires, first switch off the power supply of all devices. The communication wires between devices should be shielded twisted cable. When installing cables they should be far away from high voltage lines or other possible interference circuits as can as possible.

1. Connections of the keyboard controller controlling multiple speed dome cameras(Figure4)

2. Connections between the keyboard and the speed dome camera(Figure5)

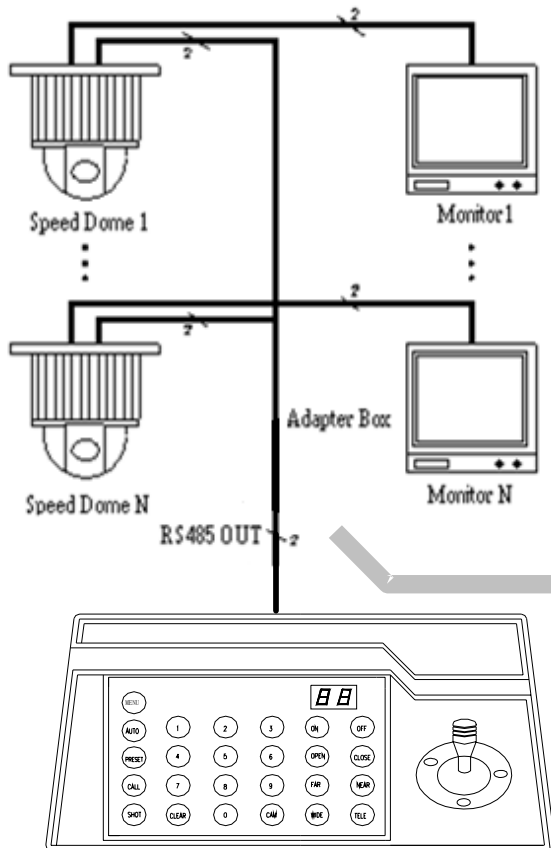

Figure4

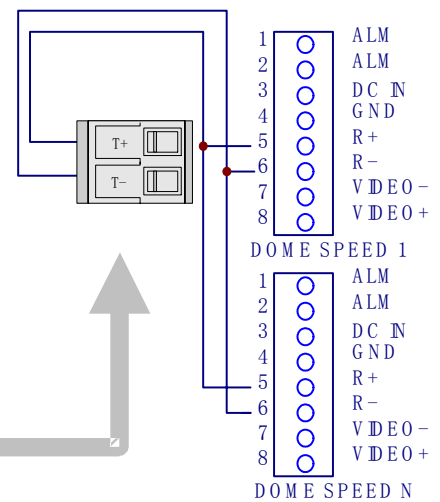

Figure5

VII. Technical Specifications:

- ◆ Communication between Speed Dome Camera and Controller: Port to multi-port and half duplex function.
- ◆ Communication connector: RS-485.
- ◆ Baud Rate of Communication: Four baud rates i.e. 2400Bps, 4800Bps, 9600Bps and 19200Bps.
- ◆ Distance of Communication: 1200 M in maximum
- ◆ Power Supply: 500 mA (the input voltage of power supply is variable for power supply's specification)
- ◆ Size: 188 × 97 × 70 (mm)
- ◆ Weight: 0.5 Kg
- ◆ Number of Controlled Speed Dome Camera up to 32.

VIII. Points for Attention:

- ◆ Please read the operation manual of the keyboard carefully before using it.
- ◆ The operation manual is mainly focused on all functions of **B01 Protocol**. For other different

protocols, operations could be something difference and those different parts will be listed on **“Supplementary Description of the Keyboard Controller”** in details.

- ◆ The keyboard takes 12V DC power supply. Please confirm the voltage and polarity before the power supply is switched on.
- ◆ Do not place the keyboard under the rain or on wet place so as to avoid short circuit or electrical shock.
- ◆ As the keyboard is a sophisticated electronic device, you should never open the case so as to avoid the occurrence of trouble.
- ◆ The keyboard has integrated multiple protocols, and you are pleased to select correct protocol and the baud rate.